

100SFQ25.5 -62

100SFQ27.5 -62

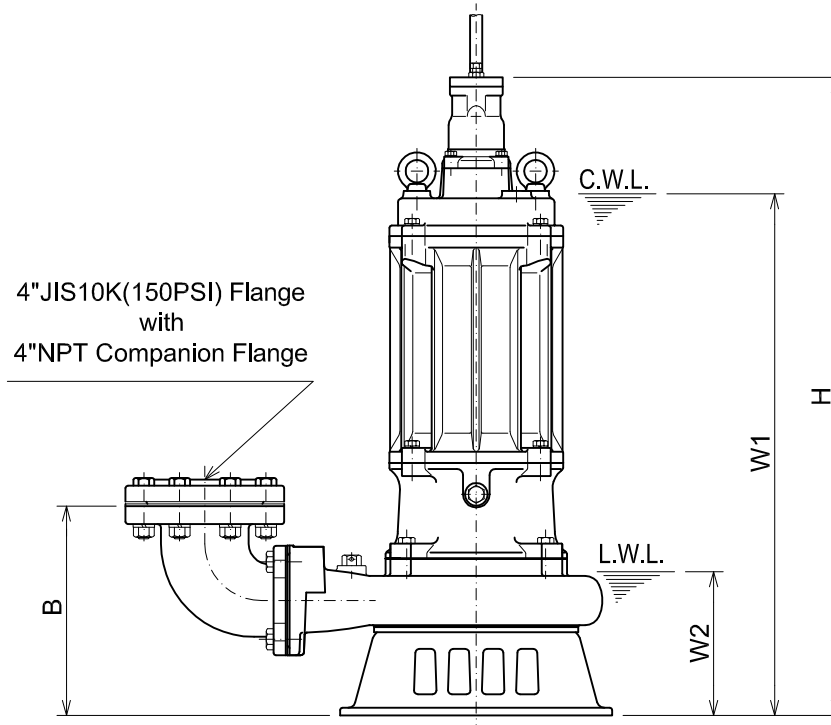
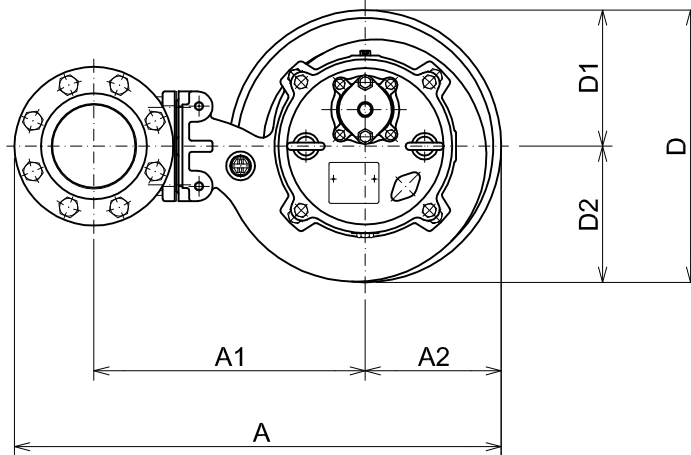

C.W.L. :Continuous running Water Level
 L.W.L. :Lowest running Water Level

DIMENSIONS:USCS(Inch)

Model	HP	NOM. SIZE	Pump & Motor								C.W.L.	L.W.L.	Wt. (lbs.)
			A	A1	A2	B	D	D1	D2	H			
100SFQ25.5 -62	7.5	4"	25 3/8	14 1/8	7 1/16	10 7/8	14 3/16	7 1/16	7 1/16	33 1/4	27 1/8	7 1/2	278
100SFQ27.5 -62	10	4"	25 3/8	14 1/8	7 1/16	10 7/8	14 3/16	7 1/16	7 1/16	33 1/4	27 1/8	7 1/2	276

DIMENSIONS:METRIC(mm)

Model	kW	NOM. SIZE	Pump & Motor								C.W.L.	L.W.L.	Wt. (kg)
			A	A1	A2	B	D	D1	D2	H			
100SFQ25.5 -62	5.5	100	644	359	180	277	360	180	180	844	690	190	126
100SFQ27.5 -62	7.5	100	644	359	180	277	360	180	180	844	690	190	125



SFQ-SERIES
ALL316SS - DEWATERING PUMPS

DIMENSIONS

TO100SFQ25.5 -62
TO100SFQ27.5 -62

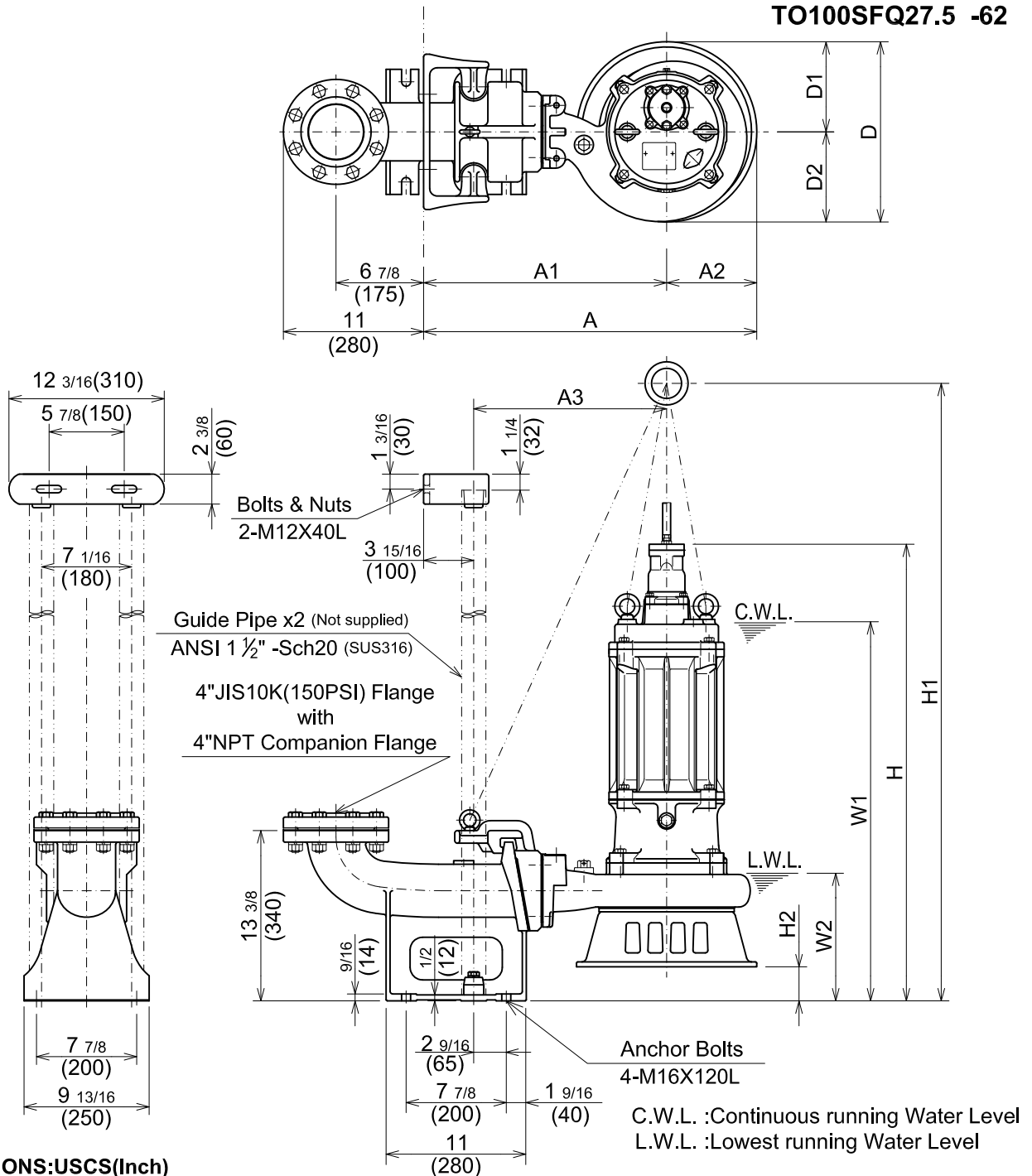

DIMENSIONS:USCS(Inch)

Model	HP	NOM. SIZE	Pump & Motor									C.W.L.	L.W.L.	Wt. (lbs.)	
			A	A1	A2	A3	D	D1	D2	H	H1				H2
TO100SFQ25.5 -62	7.5	4"	26 3/16	19 1/8	7 1/16	15 3/16	14 3/16	7 1/16	7 1/16	35 7/8	48 9/16	2 11/16	29 3/4	10	265
TO100SFQ27.5 -62	10	4"	26 3/16	19 1/8	7 1/16	15 3/16	14 3/16	7 1/16	7 1/16	35 7/8	48 9/16	2 11/16	29 3/4	10	262

DIMENSIONS:METRIC(mm)

Model	kW	NOM. SIZE	Pump & Motor									C.W.L.	L.W.L.	Wt. (kg)	
			A	A1	A2	A3	D	D1	D2	H	H1				H2
TO100SFQ25.5 -62	5.5	100	665	485	180	385	360	180	180	912	1233	68	755	255	120
TO100SFQ27.5 -62	7.5	100	665	485	180	385	360	180	180	912	1233	68	755	255	119



SFQ - SERIES

ALL 316 SS - DEWATERING PUMPS

PERFORMANCE CURVE

MODEL	BORE	HP	KW	RPM	SOLIDS DIA	LIQUID	SG.	VISCOSITY	TEMP.
(TO) 100SFQ25.5-62	4"/100mm	7.5	5.5	3545	0.79"/20mm	Water	1.0	1.123 cSt.	60°F
PUMP TYPE	PHASE	VOLTAGE	AMPERAGE		HZ	STARTING METHOD	INS. CLASS		
All 316 SS - Dewatering Pump	3	208-230/460/575	19.3-18.2 / 9.4 / 7.5		60	Direct On Line	F		
CURVE No.	DATE	PHASE	VOLTAGE	AMPERAGE	HZ	STARTING METHOD	INS. CLASS		
-	-	-	-	-	-	-	-		

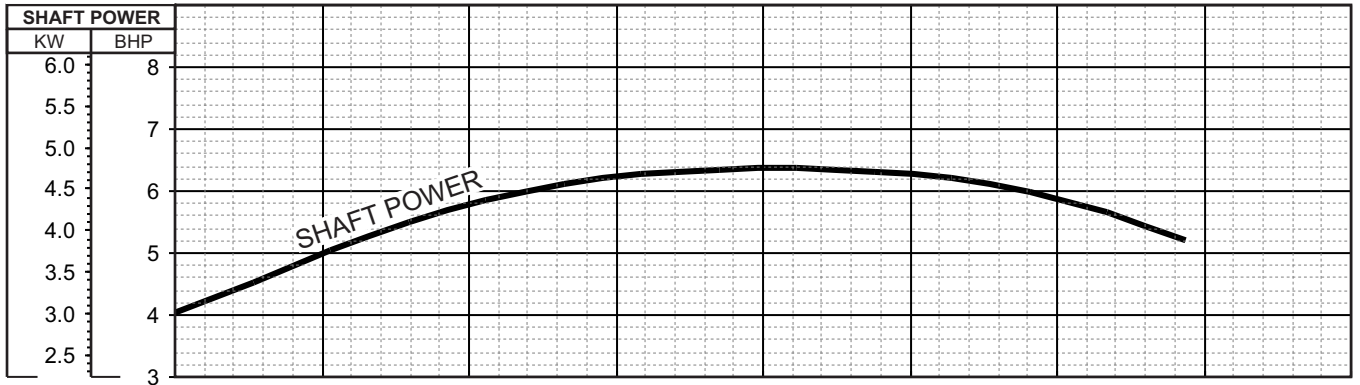
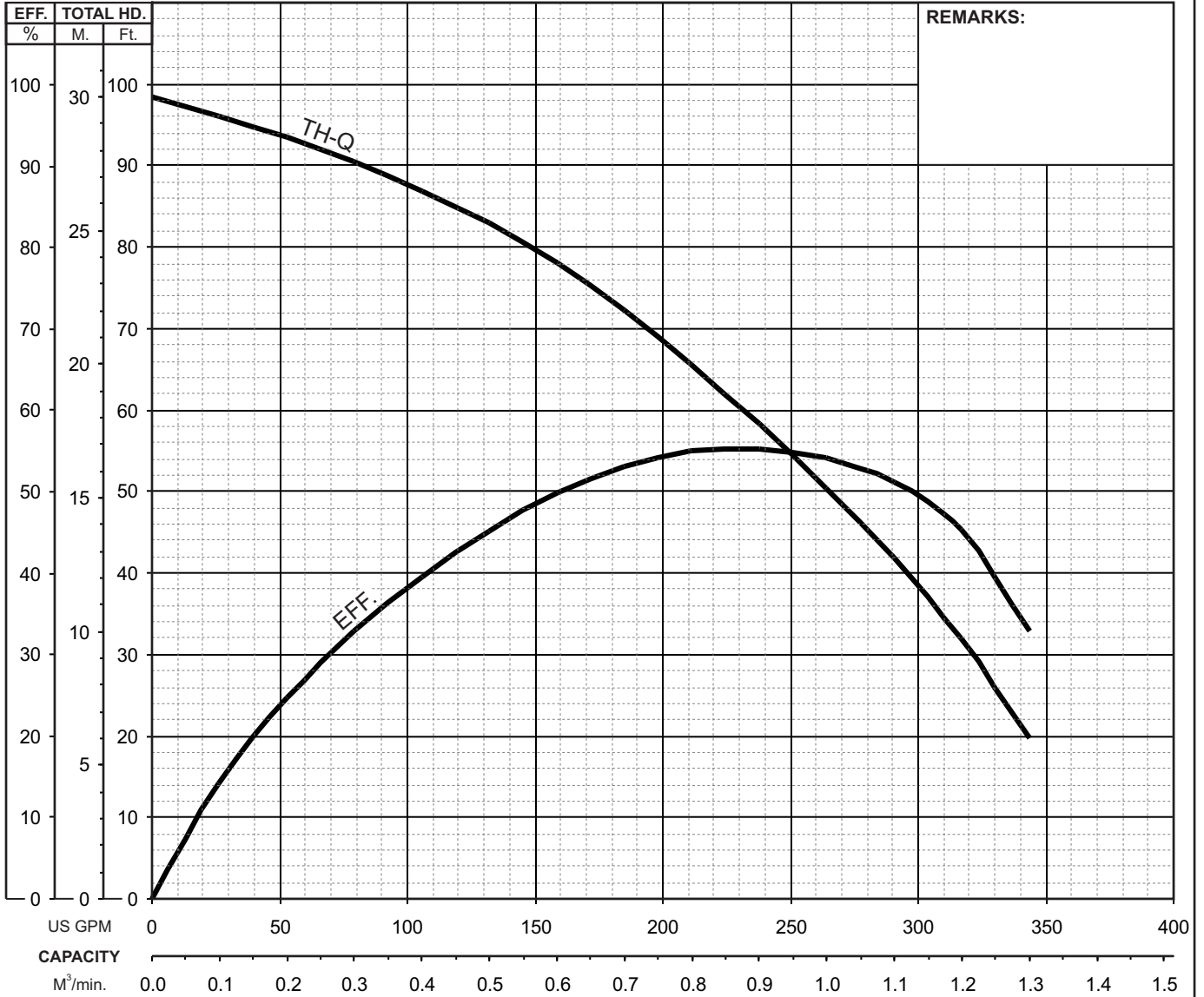

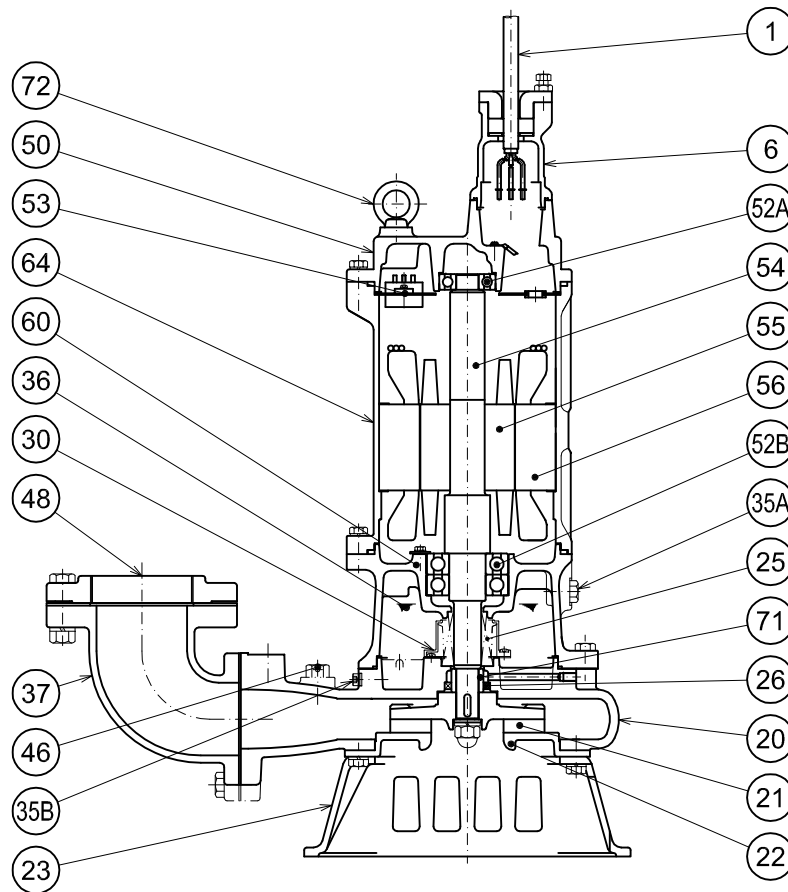
100SFQ25.5 -62

PART#	DESCRIPTION	MAIN MATERIAL / NOTE	RELATED ASTM,AISI CODE	RELATED EN CODE	QTY
1	Power Cable	Chloroprene Sheath AWG 12/4-32ft			1
6	Stuffing Box	Stainless Steel Casting	A743 CF-8M	GX5CrNiMo19-11-2	1
20	Pump Casing	Stainless Steel Casting	A743 CF-8M	GX5CrNiMo19-11-2	1
21	Impeller	Stainless Steel Casting	A743 CF-8M	GX5CrNiMo19-11-2	1
22	Suction Cover	Stainless Steel Casting	A743 CF-8M	GX5CrNiMo19-11-2	1
23	Suction Strainer	Stainless Steel Casting	A743 CF-8M	GX5CrNiMo19-11-2	1
25	Mechanical Seal	Silicon Carbide / X-30W			1
26	Oil Seal	NBR / TC35508			1
30	Oil Lifter	PBT Resin W/GF40			1
35A	Oil Plug	Stainless Steel	S 31600	1.4401	1
35B	Oil Plug	Stainless Steel	S 31600	1.4401	1
36	Lubricant	Turbine Oil ISO VG32 or SAE 10W-20			
37	Discharge Bend	Stainless Steel Casting	A743 CF-8M	GX5CrNiMo19-11-2	1
46	Air Release Valve	Stainless Steel	S 31600	1.4401	1
48	Companion Flange	Stainless Steel Casting / NPT 4"	A743 CF-8M	GX5CrNiMo19-11-2	1
50	Motor Bracket	Stainless Steel Casting	A743 CF-8M	GX5CrNiMo19-11-2	1
52A	Upper Bearing	#6305ZZC3			1
52B	Lower Bearing	#6308ZZD2C3			1
53	Motor Protector				1
54	Shaft	Stainless Steel	S 31600	1.4401	1
55	Rotor				1
56	Stator				1
60	Bearing Housing	Stainless Steel Casting	A743 CF-8M	GX5CrNiMo19-11-2	1
64	Motor Housing	Stainless Steel Casting	A743 CF-8M	GX5CrNiMo19-11-2	1
71	Shaft Sleeve	Stainless Steel	S 31600	1.4401	1
72	Lifting Lug Bolt	Stainless Steel	S 31600	1.4401	2

PARTS LIST		CORROSION RESISTANT PUMP				8/31/2016
ITEM	PART No.	DESCRIPTION	QTY	SIZE	MATERIAL	NOTES
1	001-004-64	Cabtyre Cable Set (32') 60Hz(USA)	1	2PNCT4Cx3.5mm2	SFQ	
2	140-079-36	Hex.Bolt	2	M10x40	SUS316	included in ITEM#1 Cable Ass'y
3	141-006-22	Hex.Nut	2	M10	SUS316	included in ITEM#1 Cable Ass'y
4	003-112-18	Gland	1	No.2	SCS14	included in ITEM#1 Cable Ass'y
5	004-131-16	Cable Bush	1	d17xd49x20l	CR	included in ITEM#1 Cable Ass'y
6	005-120-15	Bush Washer	1	d19.5xd49x3.2t	SPC	included in ITEM#1 Cable Ass'y
7	140-056-24	Hex.Bolt	4	M8x30	SUS316	
8	142-163-21	Spring Washer	4	M8	SUS316	
9	006-101-26	Stuffing Box	1	55/75-CL	SCS14	included in ITEM#1 Cable Ass'y
10	122-126-20	O-Ring	1	G-75(74.4xd3.1)	VITON	*
11	143-086-22	Pan Screw (w/Spring Washer)	1	M4x8	SWRM	
12	142-160-31	Spring Washer	1	M4	SWRH	
13	009-130-10	Terminal	1	R-5.5-4	CU	included in ITEM#1 Cable Ass'y
14	009-275-18	Compression type Terminal	6	TGNB-5.5(Insulated)	CU	included in ITEM#1 Cable Ass'y
15	072-102-35	Eye Bolt	2	M12	SUS316	
16	140-078-22	Hex.Bolt	4	M10x35	SUS316	
17	142-164-22	Spring Washer	4	M10	SUS316	
18	050-000-05	Motor Bracket	1		SCS14	
19	122-000-29	O-Ring	1	G-200(199.3xd5.7)	VITON	*
20	142-197-11	Wave Washer	1	6305	SK5	
21	052-108-13	Bearing	1	6305ZZC3		
22	143-126-12	Pan Screw (w/Spring Washer/Plain Washer)	2	M4x12	SWRM	
23	053-506-18	Motor Protector 460V-60Hz(USA)	1	KA314-HMXL00	(B.C)	
24	058-184-11	Lead Wire Protection Plate	1	d90xd224x1.6t	SPHC	
25	055-000-15	Rotor	1Set			
26	147-080-15	Impeller Key	1	7x7x18L	SUS316	
27	056-000-16	Stator 460V-60Hz(USA)	1Set			
28	147-000-03	Key	1	7x3.5x40L	S45C	
29	140-079-23	Hex.Bolt	4	M10x40	SUS316	
30	142-164-22	Spring Washer	4	M10	SUS316	
31	064-000-05	Motor Frame	1		SCS14	
32	122-000-29	O-Ring	1	G-200(199.3xd5.7)	VITON	*
33	140-000-06	Hex.Bolt (w/Spring Washer/Plain Washer)	3	M6x12	SWCH	
34	052-139-13	Bearing	1Set	6308ZZD2C3		
35	140-100-24	Hex.Bolt	4	M12x45	SUS316	
36	142-165-23	Spring Washer	4	M12	SUS316	
37	060-000-08	Bearing Housing	1		SCS14	
38	122-259-23	O-Ring	1	12xd3	VITON	*

PARTS LIST		CORROSION RESISTANT PUMP				8/31/2016
ITEM	PART No.	DESCRIPTION	QTY	SIZE	MATERIAL	NOTES
39	035-102-14	Oil Plug	1	M12x16(B=21)	SUS316	
40	025-191-19	Mechanical Seal	1	X-30W	SiC	
41	143-070-23	Pan Screw	2	M5x6	SWRM	
42	030-142-11	Oil Lifter	1	H-30(A)(T)	Resin	
43	143-070-10	Pan Screw	3	M5x6	SWRM	
44	030-151-13	Seal Stopper	1	H-30(A)(T)	SPCC	
45	122-406-14	O-Ring	1	195xd3.1	VITON	*
46	046-000-04	Air Release Valve	1	PT-1/2	SUS316	
47	035-109-11	Oil Plug	1	M8x12	SUS316	
48	121-248-13	Packing	1	d8.2xd13.5x2t	PE	*
49	020-000-96	Pump Casing	1	80SFQ25.5/27.5/211	SCS14	
50	026-000-26	Oil Seal	1	TC-35508	VITON	
51	071-344-12	Shaft Sleeve	1	80SFQ25.5/7.5/11	SUS316	
52	040-117-18	Impeller Shim		d25.2xd38x0.3t	SUS316	
53	021-377-19	Impeller (60Hz)	1	100SFQ25.5-62	SCS14	
54	142-130-32	Plain Washer	1	M16	SUS316	
55	142-166-24	Spring Washer	1	M16	SUS316	
56	141-033-28	Hex.Cap Nut	1	M16	SUS316	
57	120-121-16	Packing		d204xd264x0.3t	PE	
58	022-308-12	Suction Cover	1	55-CL	SCS14	
59	142-165-23	Spring Washer	3	M12	SUS316	
60	140-096-26	Hex.Bolt	3	M12x25	SUS316	
61	023-123-27	Pump Stand	1	55/110-CL	SCS14	
62	142-165-23	Spring Washer	3	M12	SUS316	
63	140-099-29	Hex.Bolt	3	M12x40	SUS316	
64	140-130-23	Hex.Bolt	8	M16x70	SUS316	
65	048-194-13	Screwed Flange	1	NPT-4(55-CL2)	SCS14	
66	121-148-12	Packing	1	JIS10Kx100mm	Cork	
67	037-114-28	Discharge Bend	1	80x100mm	SCS14	
68	142-166-24	Spring Washer	8	M16	SUS316	
69	141-008-24	Hex.Nut	8	M16	SUS316	
70	142-166-24	Spring Washer	4	M16	SUS316	
71	140-124-24	Hex.Bolt	4	M16x40	SUS316	
72	121-154-11	Packing	1	145mm2(P.C.145)	Cork	*
	173-000-51	Packing O-Ring Set	1Set	(Marked by *)		
10	122-126-20	O-Ring (S.Box)	1	G-75(74.4xd3.1)	VITON	*
19	122-000-29	O-Ring (M.Bracket/M.Frame)	1	G-200(199.3xd5.7)	VITON	*
32	122-000-29	O-Ring (M.Frame/Brg.Housing)	1	G-200(199.3xd5.7)	VITON	*



MODEL 100SFQ25.5-62

PARTS LIST		CORROSION RESISTANT PUMP				8/31/2016
ITEM	PART No.	DESCRIPTION	QTY	SIZE	MATERIAL	NOTES
38	122-259-23	O-Ring (Oil Plug)	1	12xd3	VITON	*
45	122-406-14	O-Ring (Brg.Housing/O.Casing)	1	195xd3.1	VITON	*
48	121-248-13	Packing (Oil Plug)	1	d8.2xd13.5x2t	PE	*
72	121-154-11	Packing (Discharge Bend)	1	145mm2(P.C.145)	Cork	*
		Lubricant		Turbine Oil VG32 2,250ml		

PARTS LIST		CORROSION RESISTANT PUMP				8/31/2016
ITEM	PART No.	DESCRIPTION	QTY	SIZE	MATERIAL	NOTES

EXPLODED VIEW

80SFQ25. 5-52/62

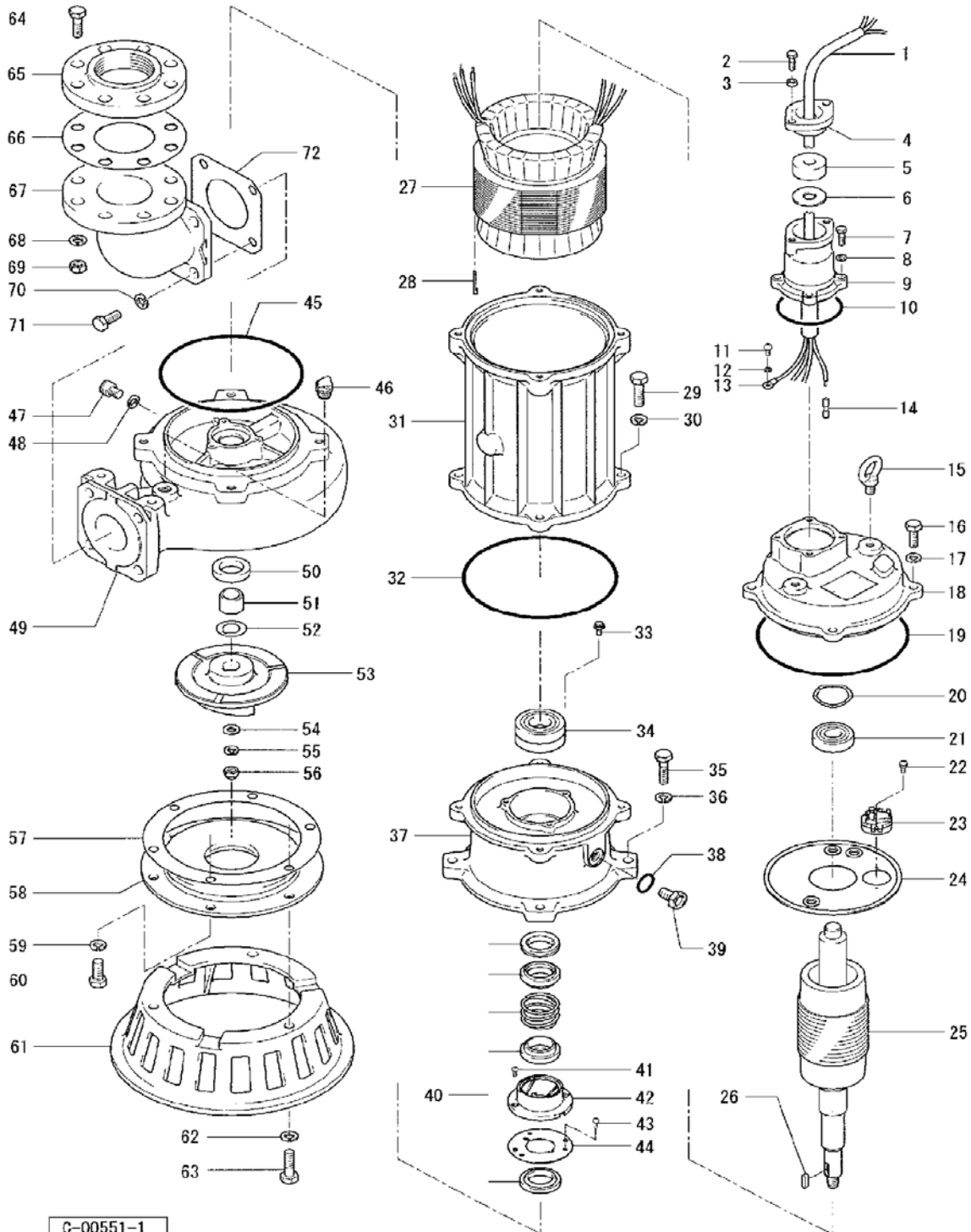

C-00551-1